

# DATASHEET

Patent Pending

## GPS Antenna Filter model UFL-1575-339

Family of filters designed to be used with either active or passive antennas, to enhance receiver performance, particularly in urban and high Electromagnetic density environments, where there is a prevalence of strong signals. In such environments, large out of band signals have the ability to control the performance of your receiver's early stages, where typically, selectivity is poor. This condition will cause your receiver to perform poorly either on a continuous or periodic fashion, depending on the nature of the controlling signal.

This product is designed to filter both, the RF (Radio Frequency) channel (please be sure to select the filter that covers the band you are operating on), and the DC supply to the antenna (active antenna). Often, active antennas use the same coaxial cable to deliver power and signal. This feature is fully supported.

The standard interface of this product line is an MMCX female connector. Installs or mounts using 2-4 screws, sizes #2-56 to #4-40 or M2 to M3.

<b>Frequency range:</b>	1565-1585 MHz (GPS)
<b>Insertion Loss:</b>	8 dB (maximum)
<b>Rejection:</b>	50 dB (typical) $\pm$ 100 MHz
<b>Nominal Impedance:</b>	50 ohm (RF), Open (DC)
<b>VSWR:</b>	2.0 (maximum)
<b>RF Power:</b>	0.1 Watt CW (maximum)
<b>Input DC Voltage:</b>	30 Volt (maximum)
<b>Voltage Drop:</b>	1.9 Volt @ 250 mA
<b>Maximum DC Current:</b>	250 mA (milliamperes)
<b>Connector:</b>	MMCX, Female
<b>Dimensions:</b>	41 x 26 x 11 mm 1.6" x 1.0" x 0.4"
<b>Mounting:</b>	2 to 4 screws (M2 - M3) or (#2-56 - #4-40)
<b>Operating Temperatures:</b>	-40°C to +85°C
<b>Weight:</b>	30 g / 0.06 lbs

**NOTES:** Patent Pending

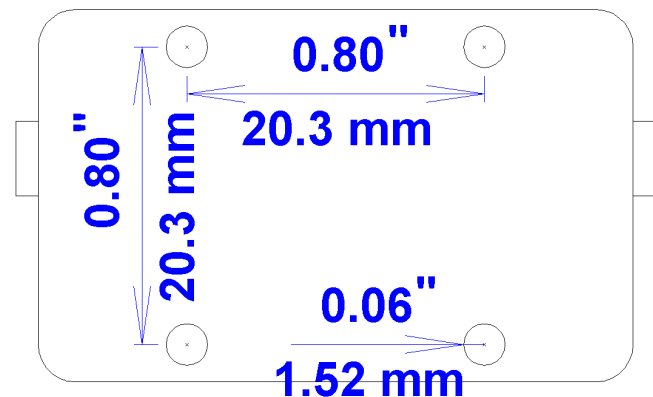
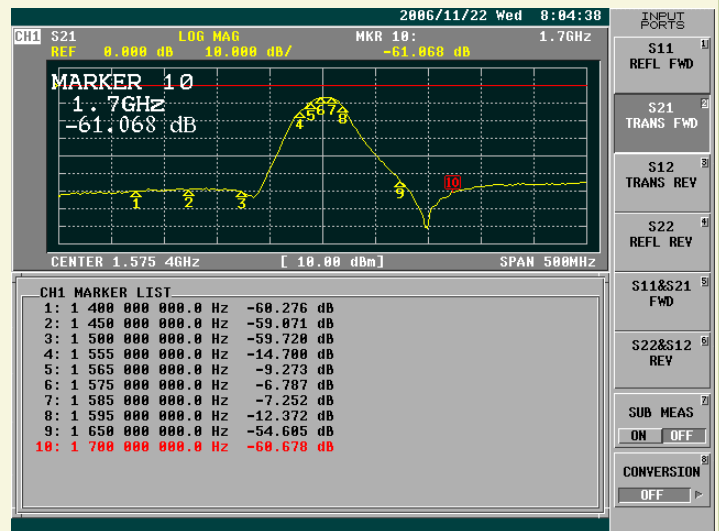

antennas.us

a Sales division of Myers Engineering International, Inc.